



GENUINE LAND ROVER / MANTEC SPARE WHEEL CARRIER FOR DEFENDER FITTING GUIDE

THOMASPERFORMANCE.CO.UK \ INFO@THOMASPERFORMANCE.CO.UK

Genuine MANTEC Swing Away Wheel Carrier / Land Rover Genuine parts.

The unique patented piston carrier allows the same swinging action to open the back door while still attached to the spare wheel carrier. All the weight of the spare wheel is taken off the back door by the spare wheel carrier, mounted onto the chassis. It is important you make sure the back door of the Defender has not been modified or changed as the backing plate utilises the existing holes.

Mantec's swing away carrier fits Defender 90 and 110 models and makes the rear door automatically swings out of the way. Smooth action is aided by a smooth strut.

Our kits come partially assembled, meaning you can simply bolt the swing-away to your Defender in 30minutes.

FITTING INSTRUCTIONS:

You may find that you have surplus nuts & bolts left over after having fitted the kit and there may be small differences in the kit to the diagram below but, not to worry - this is normal.

DOOR PLATE AND PISTON ASSEMBLY

Remove rear door trim.

Remove existing carrier and retain bolts for fitting new door plate.

Fit new door plate (7) using original bolts

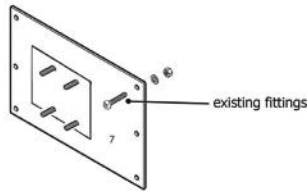

PLEASE NOTE THERE IS NO NEED TO DRILL WITH THIS MODEL

The piston (8) can now be fitted on the studs on the door plate using M8 washer x4 and M8 Nut Nylock x4 provided.

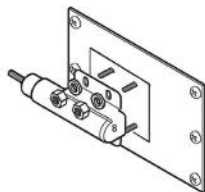

FINAL FITTING

Open door and wheel carrier together and draw the piston in to the slot in the wheel carrier frame. Ensure that the rubber washer (9) is located between the piston and carrier frame as shown.

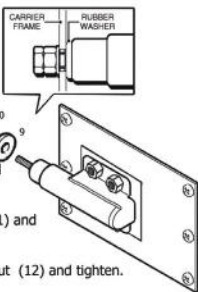

Close the door and carrier, centralise piston bolt. Fully open door and check that the piston bolt is still in a central position. If the piston bolt is not central - realign the piston bracket on the slotted holes to suit.

When you are happy with the alignment fit steel washer (10) and nut (11) and tighten until the rubber washer (9) is pinched.

Check that the carrier/door opens and closes satisfactorily, fit locking nut (12) and tighten.

Tighten all remaining fittings. Refit any internal trim and replace spare road wheel.

Top Hinge



Bottom Hinge & Backing Plates



Piston Carrier Assembly



M10 x 30 Bolt Qty 2



M10 Washer Qty 2



M8 x 25 Bolt Qty 4



M12 x 90 Bolt Qty 2



M12 Washer



M12 Rubber Washer



Door Plate



M8 Washer Flat Qty 8



M12 Washer Qty 4



M12 Nut Nylock Qty 2



Frame Assembly

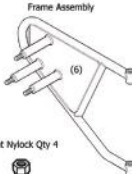

M8 Nut Nylock Qty 4



M12 Penny Washer Qty 2



Nylon Washer Qty 2



M12 Nut lock Nut (12)



M12 Nut (11)



PLEASE NOTE THE FOLLOWING :

To ensure that the mechanism works to it's full potential the SWING AWAY 50 must be fitted squarely to the body and will require final adjustments to achieve this.

During assembly only "pinch tighten" bolts, on completion when a satisfactory fit is achieved all fasteners will then need to be fully tightened.

Before drilling check that there are no cables or other obstructions in the effected area, as necessary carefully remove any internal trim.

Remove spare road wheel.

BOTTOM HINGE

Remove the two fixings, remove and discard grab handle existing nut plate and fixings.

Position the bottom hinge (1), locate the nut plates (2) and secure with the four M8 bolts and washers.

NOTE: The nut plates (2) go behind the rear cross member.

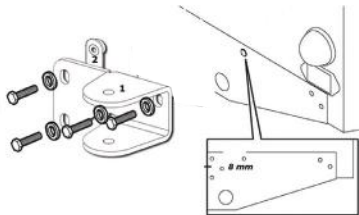

NOTE:

To ensure that the wheel carrier fits squarely the upper and lower hinges should be an equal distance from the body edge.

TOP HINGE

Remove the two existing rivets from the body capping and drill out the two holes (3) to 11mm for M10 Bolts.

NOTE: Some vehicles may have only one rivet in this location. (3)
If this is the case, remove the rivet closest to the door edge, then use the top hinge bracket as a template to drill the second hole.

Position the top hinge (4) as shown, locate the nut plate (5) and secure with the two M10 bolts and washers.

NOTE: The nut plate (5) goes behind the body work, inside the vehicle.

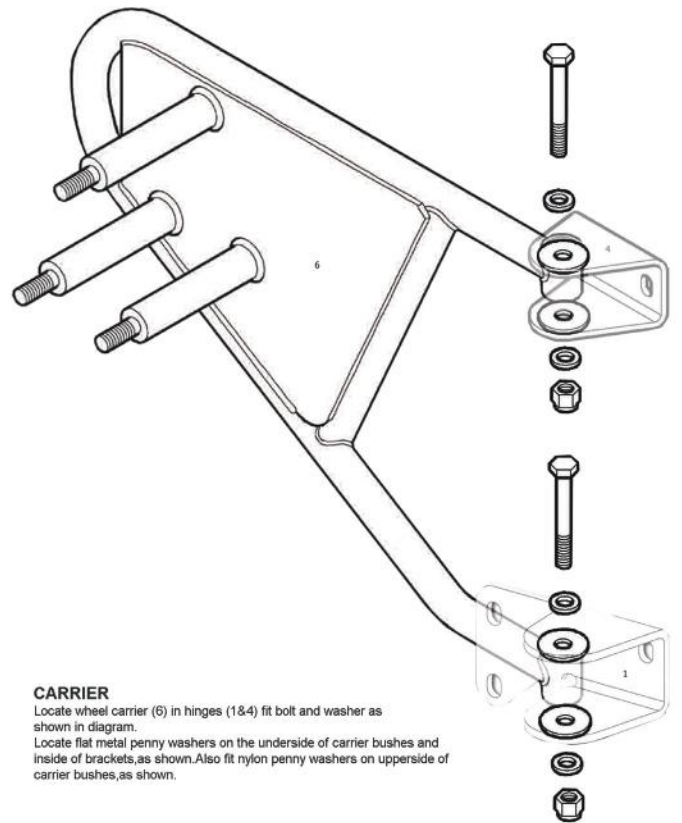
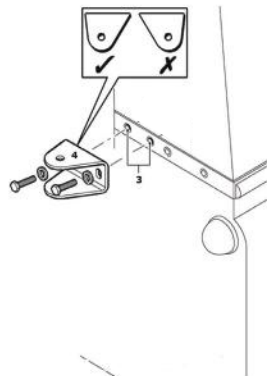

CARRIER

Locate wheel carrier (6) in hinges (1&4) fit bolt and washer as shown in diagram.
Locate flat metal penny washers on the underside of carrier bushes and inside of brackets, as shown. Also fit nylon penny washers on upperside of carrier bushes, as shown.

Thank you for your purchase from thomasperformance.co.uk

If you have any questions in regards to this product and/or fitting, drop us an email on info@thomasperformance.co.uk and one of the team will get back to you as soon as possible.

© Copyright Thomas Performance. All Rights Reserved.